

Easy-to-Customize

Trimmer base assembly with Square base plate



Convenient for cutting workpiece using guide rule, auxiliary wood fence

Offset base plate with Grip assembly



Convenient for cutting wide workpiece

Plunge base assembly with Side grip



Convenient for cutting while holding weight on one of the two handles of the base

Trimmer base with Grip attachment set



Convenient for trimming while holding two handles of the Trimmer base

Trimmer base assembly with Straight guide

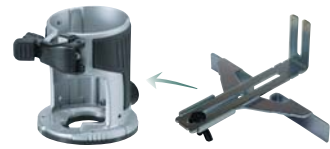

Straight guide Part No. 122391-0

Trimmer base assembly with Trimmer guide assembly



Trimmer guide assembly Part No. 122703-7

Plunge base assembly with Guide rail adapter set, Guide rail & Clamp set

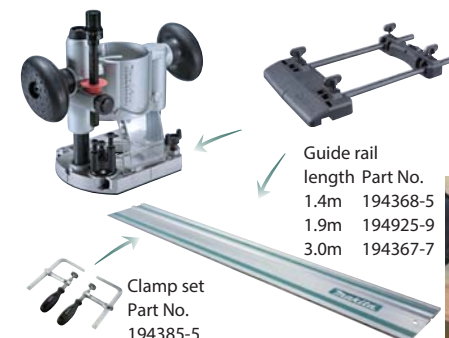

Guide rail adapter set Part No. 194579-2

Guide rail length Part No. 1.4m 194368-5 1.9m 194925-9 3.0m 194367-7

Clamp set Part No. 194385-5

Collet cone

Size	Part No.
8mm	763618-5
3/8"	763619-3
6mm	763636-3
1/4"	763637-1

Base plate

	Part No.
Trimmer base plate	454842-8
Plunge base plate	450819-1
Tilt base plate	413150-6
Offset base plate	413148-3

Plunge base assembly with Straight guide & Dust nozzle



Dust nozzle Part No. 194733-8

Guide holder set Part No. 195564-8

Straight guide (with auxiliary wood) Part No. 122391-0

Straight guide with micro adjustment (Alumi w/o mark of origin) Part No. 195136-9

Straight guide Part No. 164834-6

Templet guide

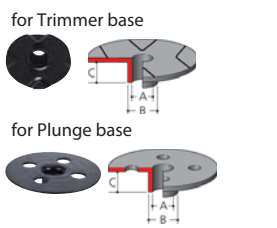

A(mm)	B(mm)	C(mm)	Part No.
for Trimmer base			
8	10	9.5	343577-5
for Plunge base			
7.7	9.5	11.5	164379-4
9	11	13	164775-6
10	12	9	164388-3
11	12.7	13	164776-4
14	17	20	165366-6
14.5	16	13	193043-0
18	20	13	164393-0
22	24	13	165364-0
24	27	13	164470-8
25	29	15	163080-8
27	30	13	164471-6
37	40	13	165046-4
37	40	13	164472-4

Cordless Trimmer DRT50 6 mm (1/4"), 8 mm (3/8")

Variable Speed	No Load Speed (RPM)	10,000 - 30,000
Constant Speed	Plunge Capacity	with Trimmer Base: 0 - 40 mm (0" - 1-9/16") with Plunge Base: 0 - 35 mm (0" - 1-3/8")
Soft Start	Vibration Level	Rotation without Load: 2.5 m/s ² or less Cutting Grooves in MDF: 4.5 m/s ²
Dust Collection	Sound Pressure Level	78 dB(A)
Built-in Job Light	Dimensions (L x W x H)	with BL1815N / BL1820B: 134x89x208 mm (5-1/4"x3-1/2"x8-1/8") with BL1830B / BL1840B / BL1850B / BL1860B: 134x89x226 mm (5-1/4"x3-1/2"x8-7/8")
Carrying Case	Net weight	1.8 - 2.1 kg (3.9 - 4.6 lbs.)

Standard Equipment: Collet Cone, Trimmer Base Assembly, Straight Guide Assembly, Templet Guide, Wrench x2, Trimmer Guide, Straight Bit, Battery, Charger

The weight may differ depending on the attachment(s), including the battery cartridge. The lightest and heaviest combination, according to EPTA-Procedure 01/2014, are shown in the table. Items of standard equipment and specifications may vary by country or area.

Makita® Cordless Trimmer DRT50 6 mm (1/4"), 8 mm (3/8")

Cordless for easy maneuverability and 4 different bases for added versatility

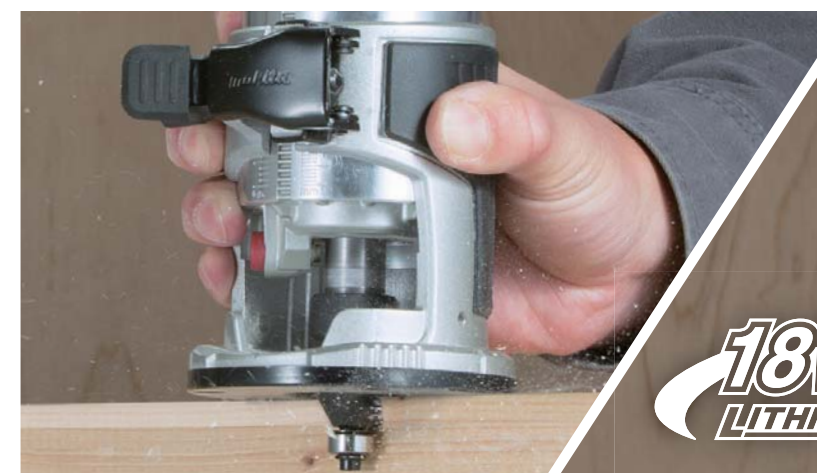



Cordless for easy maneuverability

18V LITHIUM-ION
Powered by LXT 18V Li-ion batteries

BL motor delivers the power and performance for corded demands

BL MOTOR

High durability and accuracy obtained by using aluminum for body housing

Accepts 6mm & 8mm collets, 1/4" & 3/8" collets.



Push button switch

Lock/unlock button

On/off switch button

Variable speed control by dial

Shaft lock, Flat-top design and Horizontally installed power supply cord provides stability for easier bit change.

Dual LED job lights illuminate cutting edge and increase visibility



Available in various combinations for added versatility



with Trimmer base

Round base for smooth and fast cutting with easy handling

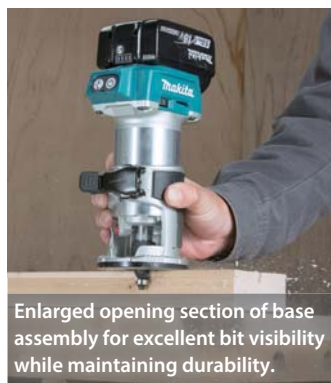

Enlarged opening section of base assembly for excellent bit visibility while maintaining durability.

Non-slip elastomer-covered body grip for increased operator comfort.

Precision cutting depth adjustment

Simple and efficient base lock system

High durability and accuracy obtained by using aluminum for trimmer base

Replaceable, non-marring plastic base plate for protection of trimmer base and smooth sliding on work surface

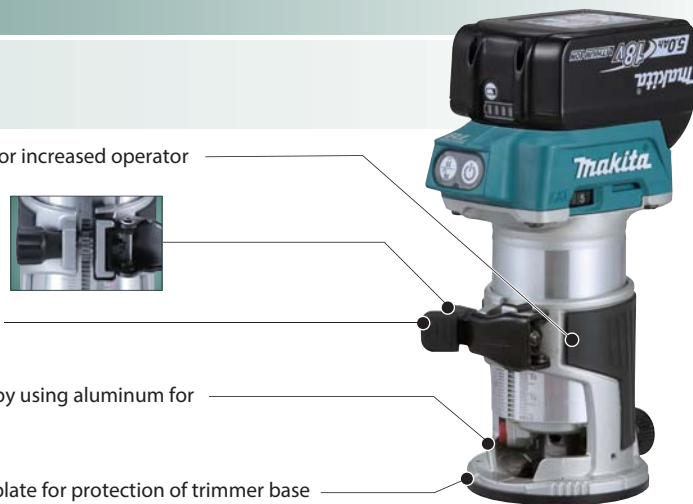

with Plunge base

Precision cutting depth adjustment
Plunge capacity: 0 - 35mm (0 - 1-3/8")



Ergonomically contoured knob



Optional Fine adjusting straight style handles

Easy-to-operate lock lever

Rubberized soft grip

3 stage cut depth adjustment

High durability and accuracy obtained by using aluminum for plunge base

Replaceable, non-marring plastic base plate for protection of plunge base and smooth sliding on work surface



with Tilt base

Ergonomic body grip easy-to-grasp with one hand
Tilting capacity: -30° to 45°

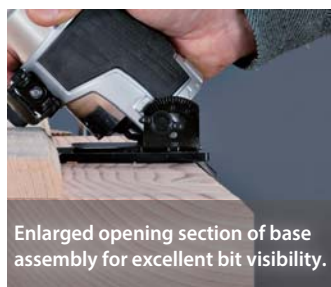

Enlarged opening section of base assembly for excellent bit visibility.

Non-slip elastomer-covered body grip for increased operator comfort.

Precision cutting depth adjustment

Simple and efficient base lock system

High durability and accuracy obtained by using aluminum for base holder

Replaceable, non-marring plastic base plate for protection of plunge base and smooth sliding on work surface



with Offset base (option)

Able to trim close to wall and tight corners with a bit set in offset position.



Able to cut close to a wall or corner-18.5mm at closest

Non-slip elastomer-covered body grip for increased operator comfort.

Simple and efficient base lock system

High durability and accuracy obtained by using aluminum for offset base

Replaceable, non-marring plastic base plate for protection of trimmer base and smooth sliding on work surface

